



AV680RX 5.8GHZ A/V RECEIVER KIT Rev-C Hardware

INTRODUCTION

Thanks to this handy kit, building a high performance 5.8GHz A/V receiver has never been easier. The kit provides a custom printed circuit board set and quality electronic components.

NOTICE: This kit requires assembly and is NOT recommended to beginners. It is suitable for amateur radio hobbyists, RF technicians, and engineers. The builder must have good quality soldering tools, an anti-static work environment, and electronic assembly experience.

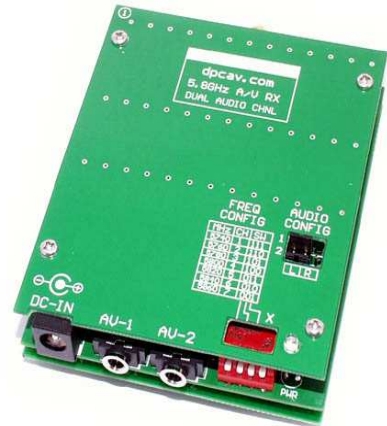

BILL OF MATERIALS

QTY	DESCRIPTION	DESIGNATOR	NOTES
4	.1uF Cap	C3, C5, C11, C12	
4	47uF Cap	C1, C2, C7, C9	Observe polarity
4	470uF/10V Cap	C4, C6, C8, C10	Observe polarity
2	2.2 1/8W Resistor	R4, R5	Red/Red/Black
1	220 1/8W Resistor	R4	Red/Red/Brown
3	2.2K 1/8W Resistor	R1, R2, R3	Red/Red/Red
1	27uH Inductor	L1	
1	1N4001 Diode	D1	Observe polarity
1	Green LED	PWR	Observe polarity
1	LM2940T-5.0 VReg IC U1		
2	3-Pin Vertical Header	J5, J6	
2	Jumper Shunt	J5, J6 Assy	See Text for shunt installation
2	1/8" Phone Jack	J2, J3	
1	4-Pos DIP Switch	SW	
1	2.1mm DC Jack	J1	
1	2.1mm DC Plug	J1 Assy	
1	SMA-RP Connector	N/A	Antenna RF connector
1	AWM680RX RF Module		
8	2-56 x 1/8" Screws	Cover Assy	
4	2-56 x 7/16" Spacers	Cover Assy	Female-Female, Top Cover
4	2-56 x 3/16" Spacers	Cover Assy	Male-Female, Bottom cover
4	Rubber Feet	Cover Assy	
1	Printed Circuit Board Set	PCB, Rev-C	3-piece PCB set (Top/Main/Bottom)

RECOMMENDED ACCESSORIES (available from www.dpcav.com)

- 5.8GHz 8dBi Patch Antenna, #HG5808P-SMA (requires coax cable #CSR400 or #CSR316)
- 5.8GHz 5dBi Patch Antenna, #AWM5.8-ANT
- 5.8GHz 4dBi Dipole Antenna, #ANTDRP-5.8
- 5.8GHz 2dBi Dipole Antenna, #ANTTRP-5.8
- 5.8GHz 8dBi Log Periodic Antenna, #HG2458-08LPNF (requires #SMA-NM1 and #SMA-015)
- 3.5mm to RCA A/V Cable, #RSA-002

The photo below (Figure 1) shows what is included in the kit:

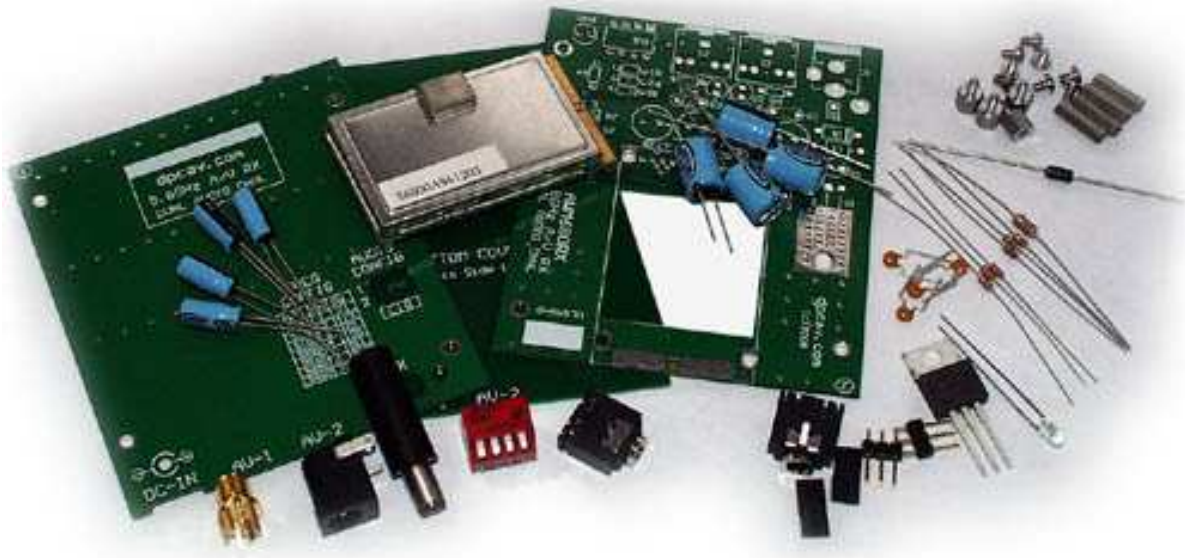

Figure 1, Contents of the Kit

These instructions are for the Rev-C hardware release. Before starting, be sure to confirm your kit is identified as Rev-C.

ASSEMBLY INSTRUCTIONS

- 1 CAPACITORS, RESISTORS, AND INDUCTORS:** See Figure 2.
 - 1.1 Install C3, C5, C11, and C12 (.1uF caps).
 - 1.2 Install C1, C2, C7, and C9 (47uF caps).
 - 1.3 Install C4, C6, C8, C10 (470uF caps).
 - 1.4 Install R5 and R6 (2.2 ohm resistors).
 - 1.5 Install R4 (220 ohm resistors).
 - 1.6 Install R1, R2, and R3 (2.2K ohm resistors).
 - 1.7 Install L1 (27uH Inductor).

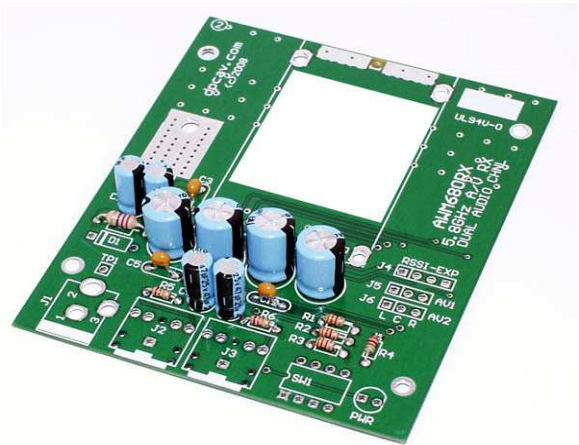

Figure 2
Caps, Resistors, and Inductors.

2 SWITCHES AND JACKS: See Figure 3.

- 2.1 Install J1 (DC power jack).
- 2.2 Install SW1 (DIP switch).
- 2.3 Install J2 and J3 (1/8" phone jacks).
- 2.4 Install J5 and J6 (3-pin headers).



Figure 3, Add the Switches and Jacks.

3 SEMICONDUCTORS: See Figure 4.

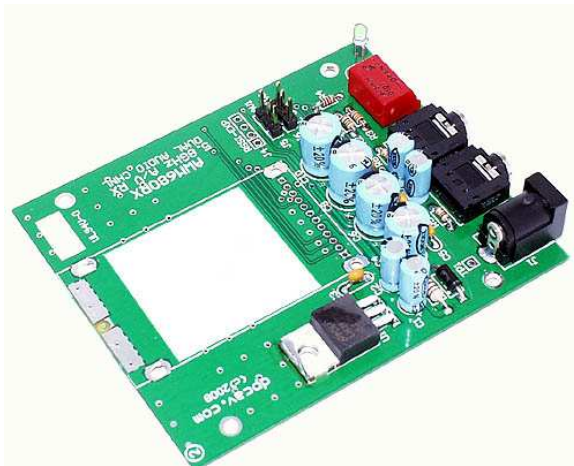

Figure 4, Add the Semiconductors.

- 3.1 Install D1 (1N4000 diode).
- 3.2 Install U1 (LM2940T-5.0 voltage regulator IC). Solder its three legs AND heavy metal tab to the circuit board.

Note: The metal tab must be soldered to the PCB. As an alternative, it can be mounted with heat sink grease and 4-40 machine screw (not included).

- 3.3 Install PWR (LED) with the anode (long lead) in the square pad. The LED must be mounted elevated so that it pokes through the hole in the top cover. We recommend that you solder the LED after the top cover is installed.

4 RF MODULE INSTALLATION: See Figure 5.

Note: The RF Module and the SMA-RP installation have changed with the Rev-C release.

- 4.1 Place the AWM681TX module on the PCB. It will have a gap between it and the PCB. It does NOT sit flush. See Figure 5 for details.
- 4.2 Before soldering the RF module in place, temporarily slide the three-legged SMA-RP connector onto the module's RF output (see Figure 7, next page). Adjust the module's placement on the PCB until the center pin of the SMA-RP is centered on top of the module's RF output trace. Once positioned, solder the module's four corners and its ten pins. Do NOT solder the SMA-RP at this time.

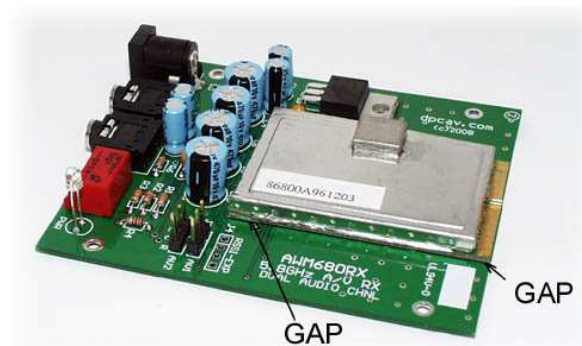

Figure 5, RF Module Installed

5 SMA-RP / ANTENNA INSTALLATION: See Figures 6, 7, and 8.



Figure 6, RF Input

- 5.1 The AWM680RX module's antenna input port is shown in Figure 6 (see red arrow). The RF ground is the gold colored PCB trace that is found on both sides of the input (see green dots).

If you will be using Wi-Fi style antennas, then go to step 5.2. If you will be using our economy PCB patch antenna (#AWM5.8-ANT), then go to step 5.4.

- 5.2 The provided SMA-RP connector is compatible with many consumer Wi-Fi style antennas. But it must be modified before installation.

As seen in figure 7, cut off the ground leg that is on the top left side. This is needed to prevent shorts to the module's nearby circuitry (on some modules there is a tiny 0402 sized SMD resistor residing there).

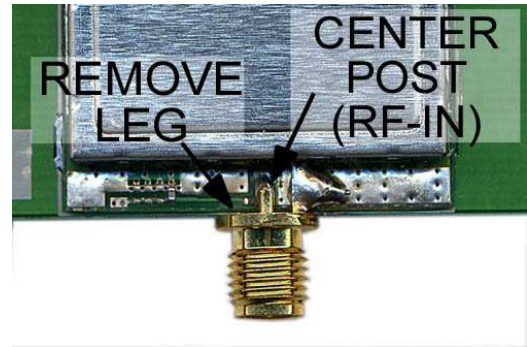

Figure 7, SMA Modification

Note: The four green dots in Figure 6 indicate the connector's ground pin alignment area. It is important to accurately align the SMA-RP's center post conductor over the top side of the module's RF input trace.

Important: When sliding the SMA-RP onto the assembly, please do not damage the tiny SMD resistor that is on the module's RF input. Actually, this resistor is unused and may be removed for a better fit of the SMA.

- 5.3 Carefully solder the three ground legs and the center post, as shown in Figure 7. Ensure the module's metal enclosure is not shorted to the center post conductor. Clean off ALL flux, even if no-clean solder was used. Do a visual inspection (do NOT use an ohmmeter).

- 5.4 Do not use the SMA-RP connector when installing dpcav.com's #AWM5.8ANT economy patch antenna (available separately). Instead, directly solder the coax to the RF port. See Figure 8.

Warning: While soldering, do not disturb the tiny SMD component installed on the modules' RF input pad.

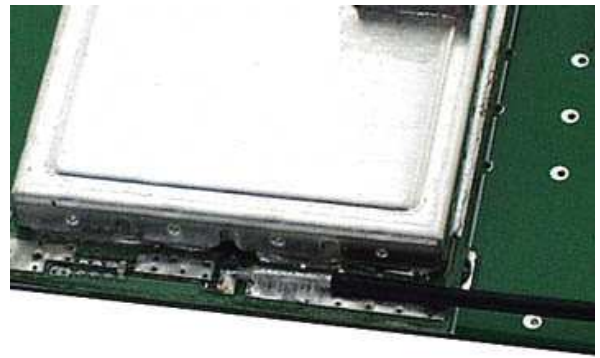

Figure 8, Coax Installation

Ensure the coax braid is not shorted to the center coax conductor on the module's RF input. Do a visual inspection (do NOT use an ohmmeter).

6 COVER INSTALLATION: See Figure 9.

- 6.1 Using the 2-56 screws, install the four female-female standoffs to the top cover.
- 6.2 Place the top cover over the main PCB and attach using the four male-female standoffs. The LED should protrude through the hole in the top cover. If the LED has not been soldered, then now is the time to do that.
- 6.3 Attach the bottom cover using the 2-56 screws.
- 6.4 Apply the four rubber feet to the bottom cover.

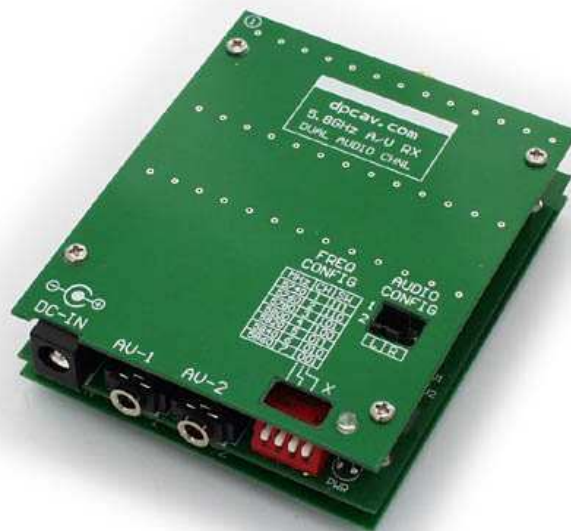

Figure 9, Covers Installed

7 FREQUENCY AND AUDIO CONFIGURATION: See Figure 10.

- 7.1 The DIP switch is used to change the received frequency. The transmitter and receiver must both be on the same RF channel. The three switches are set as follows:

CH	MHz	SW1	SW2	SW3
1	5740	ON	ON	ON
2	5760	ON	ON	OFF
3	5780	ON	OFF	ON
4	5800	ON	OFF	OFF
5	5820	OFF	ON	ON
6	5840	OFF	ON	OFF
7	5860	OFF	OFF	ON

**ON = Switch closed (Down position)
OFF = Switch open (Up position).**

Note: The forth DIP Switch (SW4) is NOT used and should be ignored.

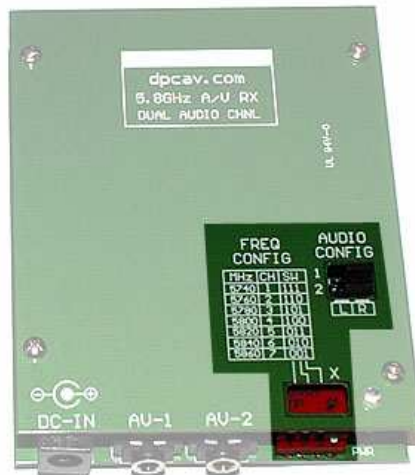

Figure 10, Freq & Audio Config.

- 7.2 The two audio channels are identified as Left (L) and Right (R). Two plug-in shunts are used to select which audio channels will appear on the AV-1 and AV-2 jacks. The top cover is labeled to help you configure the audio.

For example, in the diagram below the audio has been set so that AV-1 uses the left audio channel and AV-2 uses the right audio channel. Your settings will depend on how your preferences and application.

AUDIO CONFIG			
1	[Black Area]		
2		[Black Area]	
	L		R

Note: The black areas represent the placement of the configuration shunts for the example described above.

8 DC POWER AND AUDIO/VIDEO JACK WIRING: See Figures 11 and 12.

- 8.1 The DC input connector is center positive. Using the provided 2.1mm DC plug, create a cable to connect to your battery supply (6.5VDC to 14VDC).

Traditional AC mains operated DC wall “wart” supplies are not recommended because they are rarely regulated or filtered. If AC mains operation is needed then consult with the wall adapter supplier to ensure it is a voltage regulated design.



Figure 11,
DC Plug

- 8.2 There are two audio/video outputs (AV-1 and AV-2). They use a traditional 1/8" (3.5mm) 3-conductor miniature phone plug (available separately). The pin-out is shown in Figure 12.

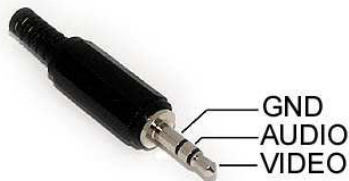

Figure 12, A/V Plug Details

Note: A slight decrease in video brightness may occur if both A/V jacks are used. If the brightness is affected too much then it will be necessary to use only one A/V jack and an external video amplifier such as our #PLV2-001.

9 AIRFLOW REQUIREMENT

- 9.1 Airflow to the internal components is required to ensure adequate cooling. Do not block the airflow.

10 TECHNICAL INFORMATION

For complete technical information, please consult the AWM680RX data sheet (available from dpcav.com's web site) and the attached schematic.

NOTICE

Digital Products Company, or their distributors, have no control over the assembly and use of this A/V RF system. As such, no liability may be assumed, nor will any liability be accepted, for any damages resulting from the use of this product. Under no circumstances will the buyer be entitled to consequential or incidental damages. By act of using it, the buyer accepts all resulting liability.

AIRWAVE AWM680 RX

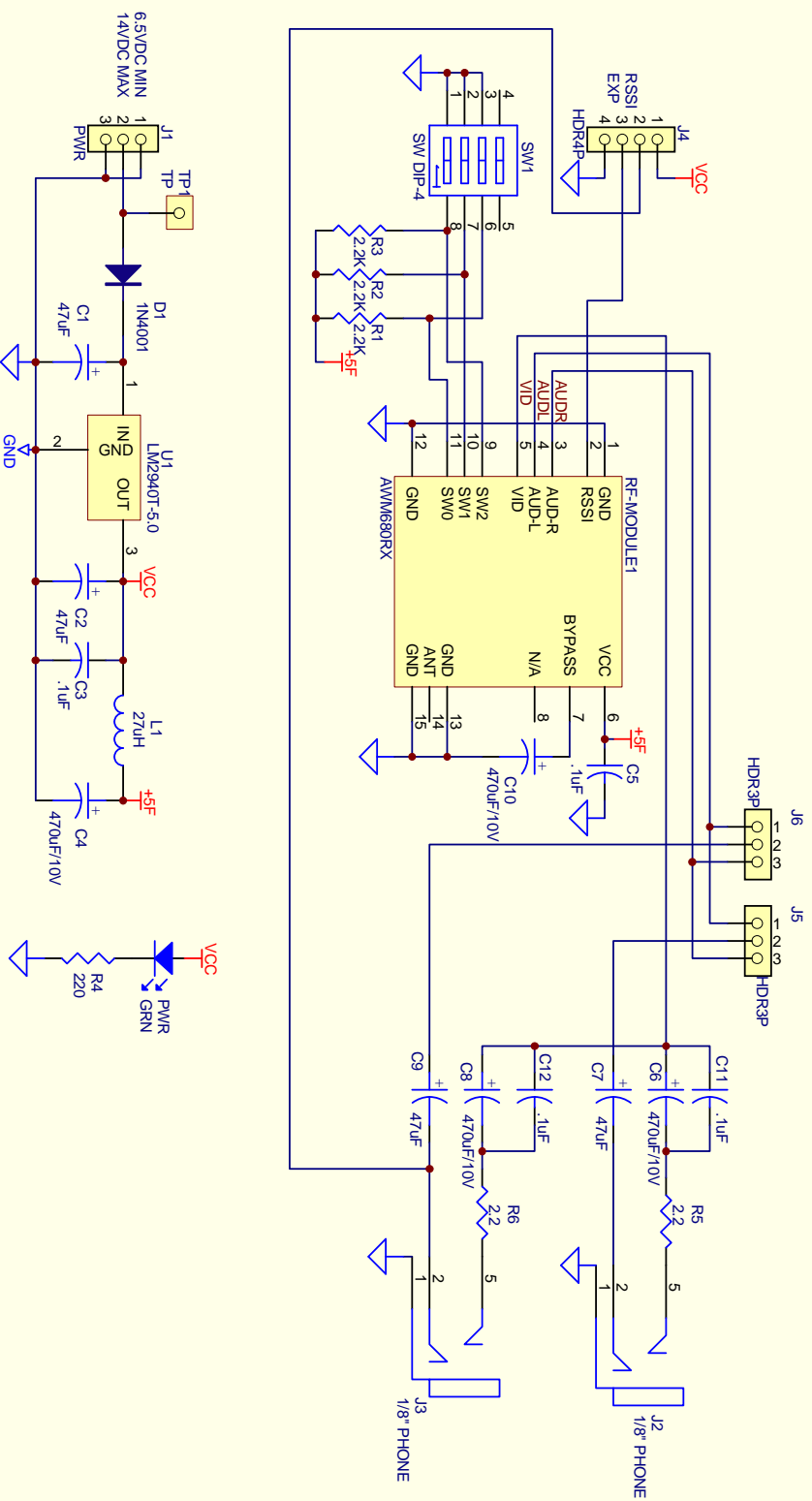

Title: 5.8GHz AV Rx KIT		Revision: C
Size: Letter	AV680RX-KIT	Sheet 1 of 1
Date: NOV-03-2008		
Copyright: 2008		

www.dpcav.com

DPC AV
AUDIO VIDEO